



Supplied Cover Wrap Specifications

Effective January 2006

CAMPUS TECHNOLOGY

In order to insure your cover wrap is accommodated correctly in our publications, please observe the following requirements. If you have any further questions, please contact your publication Production Coordinator.

These specifications are for saddle-stitched, standard-size, cover wraps specifically prepared for a 1105 Media, Inc. publication.

Magazine Trim Size:	8" x 10 ³ / ₄ "	Jog Direction:	Head/Foot*
Head Trim:	1/8"	Face Trim:	1/8"
Foot Trim:	1/8"		

▶ Label Positioning

Cover wrap must have specified area for label placement. Any label placements going to Cover 4 requires entire job to be imposed heads out, will slow mail date and incur extra cost.

* If entire job is imposed heads out, all supplied cover wraps would jog to the foot for that issue and mail offline.

Label placement can go perpendicular to spine (preferred):

- Inkjet labels must be 1/4" from all trimmed edges and cannot be placed within the center 5" across the cover.
- The size of the box for label must be 4 1/4" wide and 2 1/2" high. To avoid additional mail setup charges, cover wrap label position must be parallel to the foot (same as book).

Label placement can go parallel to spine with a polybagged issues for no additional cost.

- Paper labels must be 1/2" from spine, 1/4" from head or foot, and within 3 1/2" from head or foot.
- Inkjet labels must be 1/4" from all trimmed edges and cannot be placed within the center 5" across the cover.
- The size of the box for label must be 4 1/4" wide and 2 1/2" high.

▶ Quantity

Stated circulation PLUS any bonus circulation PLUS 3%. (Confirm on specific issue.)

▶ Due Date

All cover wraps must be received at our bindery at least two weeks prior to our mailing date. Contact your Production Coordinator for exact due dates.

▶ Pre-Approval

All anticipated cover wraps MUST be approved in advance, in writing, by the 1105 Media, Inc.'s Production Department. Otherwise, slowdown or increased bind-in charges may apply. Supply two paper dummies produced to desired size and paper stock.

After initial approval, please provide a minimum of ten printed samples of the wrap as far in advance as possible to verify specifications before binding.

Send samples to: Production Coordinator, *Campus Technology*
1105 Media, Inc., 9121 Oakdale Avenue, Suite 101, Chatsworth, CA 91311

▶ Stock

Minimum cover wrap paper weight is 60# Text. Maximum cover wrap paper weight is 100# Text. Minimum stock for return portion is 75# High Bulk.

▶ Safety

Keep live copy at least 1/8" from the trim size of insert and magazine. Perforation bindery requirements are 50/50 and must be positioned 3/8" from the gutter.

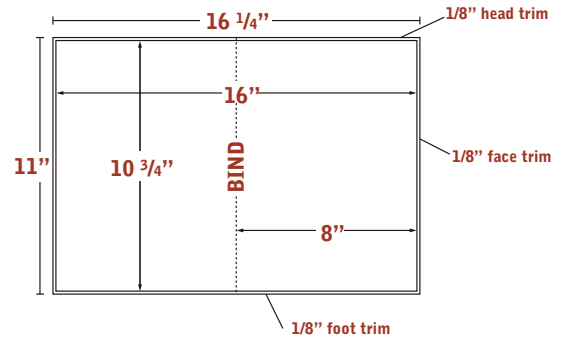

Supply Flat: 16 1/4" x 11"

▶ Packing Slip/Bill of Lading/Load Flags

Each carton and/or pallet must be labeled with the following data plus have a copy of the insert secured to the outside of the carton. All cartons must be labeled with label facing out.

- Insert/advertiser name
- Publication name & issue date
- Description of item
- Account manager's name
- Total number of full cartons in shipment (e.g. 1 of 6, 2 of 6, etc.)
- Total number of partial cartons in shipment
- Quantity in each carton
- Total quantity in shipment

This information must be separated by item for multi-item shipments. We will not be held liable for products or counts delivered to us without proper identification. Shipment of ten cartons or more must have a pallet load flag on all four sides.

▶ Palletizing Instructions

All pallets:

- Must be four-way entry
- Must have Tare Weight clearly marked on the pallet
- Must measure 40" x 48"
- Maximum pallet height is 48"
- A full pallet containing cartons, cases, etc. must measure no more than 40" x 48" x 48"

▶ Shipping Address

All inserts must be shipped prepaid to:

Cadmus Specialty Publications
c/o Drew Collison
Insert Storage Warehouse
2901 Byrd Hill Road
Richmond, VA 23228
Tel: 804-261-3124

Deliveries are only received Monday through Friday, 8am-5pm. *Deliveries outside of regular business hours will be scheduled for the following day.* To preschedule deliveries outside of regular hours, call: 804-261-3033.

Note: The contact address and phone number are provided for shipping documents only. All questions must be directed to your publication Production Coordinator.

▶ Digital Edition Requirements

All inserts are included in the Digital Edition of *Campus Technology*. This requires submission of digital files in addition to pre-printed inserts. Please submit the original native and/or PDF files used for the creation of the printed insert. Pre-printed inserts still ship directly to our bindery, but the digital files should be directed to the *Campus Technology* Production Coordinator noted below. See our Digital Advertising Specifications for more details on file formats.

▶ Contact Information

Direct all questions, changes or correspondence to:
Campus Technology, Attn: Production Coordinator
1105 Media, Inc.
9121 Oakdale Avenue, Suite 101
Chatsworth, CA 91311
Tel: 818-734-1520 x112
Fax: 818-734-1528
Email: campustechadproduction@1105media.com

▶ FTP File and Upload Information

Name your files with the magazine name, issue date and project name. All uploads should be followed by either a confirmation phone call or email message to your Production Coordinator to verify the file has been sent.

It is important that the uploaded file is placed in the designated directory for expedient access.

Host: <ftp://ads.1105media.com/>

User ID: 1105user

Password: 1105pass

Directory: /1105external/production/(publication folder)

▶ Pre-press

Ads requiring work to be done (sizing, typos, etc.) by the publisher will incur an additional charge. Advertising files are stored by the Publisher for one year, then deleted.

▶ Proofs

Provide two digital color proofs at 100% size, created from the supplied digital file, on a contract-quality, digital halftone proofing system in accordance with SWOP web coated standards (AGFA Pressmatch, Kodak Approval, DuPont Waterproof, etc.).

Laser or inkjet proofs are not considered accurate in color and are supplied for content confirmation only. If supplied, the Publisher is not responsible for color variances between the digital file and final color reproduction.

IMPORTANT NOTE: If proofs are not supplied, the Publisher reserves the right to have them made at the Advertiser's expense, and make-goods due to reproduction quality will not be honored.

▶ Digital Advertising Resources

1105 Media, Inc. publication's Media Kits and Ad Specifications

<http://www.101com.com/services/DigitalAdRes.aspx>

Digital Distribution of Advertising for Publications (DDAP)

<http://www.ddap.org>

Specifications Web Offset Publications (SWOP)

<http://www.swop.org>

<http://www.swop.org/certification.html>

Adobe Acrobat

<http://www.adobe.com/products/acrobat/main.html>