



Supplied Full-page Bind-In Insert Specifications

Effective January 2006

Redmond

In order to insure your insert is accommodated correctly in our publications, please observe the following requirements. If you have any further questions, please contact your publication Production Coordinator.

These specifications are for saddle-stitched, full-page inserts specifically prepared for a 1105 Media, Inc. publication. Insert is non-detachable. Inserts meeting these specifications will trim flush with the magazine. See additional specifications for magna-stripped or tipped inserts.

Magazine Trim Size:	8" x 10 ³ / ₄ "	Jog Direction:	Head
Head Trim:	1/8"	Min. Binding Tab:	3 ¹ / ₂ "
Face Trim:	1/8"	Foot Trim:	1/8"
Untrimmed Size:	11 ⁵ / ₈ " x 11" high (includes 3 ¹ / ₂ " binding tab)		
Final Trim Size:	11 ¹ / ₂ " x 10 ³ / ₄ " high (includes 3 ¹ / ₂ " binding tab)		
Minimum Trim Size:	7 ¹ / ₂ " x 5 ³ / ₄ " high (includes 3 ¹ / ₂ " binding tab)		

▶ Quantity

Stated circulation PLUS any bonus circulation PLUS 3%. (Confirm on specific issue.)

▶ Due Date

All inserts must be received at our bindery at least two weeks prior to our mailing date. Contact your Production Coordinator for exact due dates.

▶ Pre-Approval

All anticipated inserts MUST be approved in advance, in writing, by the 1105 Media, Inc.'s Production Department. Otherwise, slowdown or increased bind-in charges may apply. Supply two paper dummies produced to desired size and paper stock.

After initial approval, please provide a minimum of ten printed samples of the insert as far in advance as possible to verify specifications before binding.

Send samples to: Production Coordinator, *Redmond*, 1105 Media, Inc.
9121 Oakdale Avenue, Suite 101, Chatsworth, CA 91311

▶ Stock

Paper requirements vary depending on actual number of pages in the insert. Standard paper weight for a 2-page insert is 70# or 80#. Please confirm stock acceptability in advance. Heavier inserts may incur additional postage costs.

▶ Perforation (optional)

Bind edge perforation should be a minimum of 1/4" from the bind edge of the unbound card. Perforation bindery requirements are 50/50. Do not perf on the bind edge/fold.

▶ Safety

Keep live copy at least 1/8" from the trim size of insert and magazine.

▶ Shipment Preparation

Inserts must be packed and supplied without curls or tears and properly skidded with a minimum of cross-stacking. Please supply brick-stacked in 4-inch lifts. Bent corners and wrinkles should be avoided as they cause slowdown during binding. Any slowdown incurred due to poor packing is chargeable to the client. Inserts must be carton-packed with dividers between layers to avoid curling. Cartons should be crated on skids.

Inserts for multiple issues must be broken down on separate pallets or cartoned with specific quantities and labeled. They must also be properly identified on the packing slip so they can easily be broken down to avoid additional handling charges.

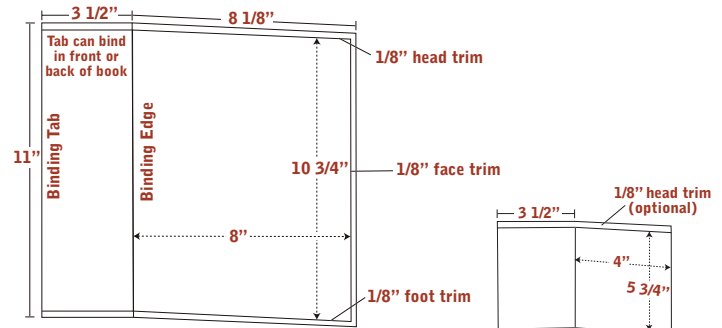

Supply flat to 11⁵/₈" x 11"

Minimum insert size

▶ Packing Slip/Bill of Lading/Load Flags

Each carton and/or pallet must be labeled with the following data plus have a copy of the insert secured to the outside of the carton. All cartons must be labeled with label facing out.

- Insert/advertiser name
- Publication name & issue date
- Description of item
- Account manager's name
- Total number of full cartons in shipment (e.g. 1 of 6, 2 of 6, etc.)
- Total number of partial cartons in shipment
- Quantity in each carton
- Total number of skids in the shipment
- Total quantity in shipment

This information must be separated by item for multi-item shipments. We will not be held liable for products or counts delivered to us without proper identification. Shipment of ten cartons or more must have a pallet load flag on all four sides.

▶ Palletizing Instructions

All pallets:

- Must be four-way entry
- Must have Tare Weight clearly marked on the pallet
- Must measure 40" x 48"
- Maximum pallet height is 48"
- A full pallet containing cartons, cases, etc. must measure no more than 40" x 48" x 48"

▶ Shipping Address

All inserts must be shipped prepaid to:

Cadmus Specialty Publications
c/o Drew Collison
Insert Storage Warehouse
2901 Byrd Hill Road
Richmond, VA 23228
Tel: 804-261-3124

Deliveries are only received Monday through Friday, 8am-5pm. *Deliveries outside of regular business hours will be scheduled for the following day.* To preschedule deliveries outside of regular hours, call: 804-261-3033.

Note: The contact address and phone number are provided for shipping documents only. All questions must be directed to your publication Production Coordinator.

▶ Digital Edition Requirements

All inserts are included in the Digital Edition of *Redmond*. This requires submission of digital files in addition to pre-printed inserts. Please submit the original native and/or PDF files used for the creation of the printed insert. Pre-printed inserts still ship directly to our bindery, but the digital files should be directed to the *Redmond* Production Coordinator noted below. See our Digital Advertising Specifications for more details on file formats.

▶ Contact Information

Direct all questions, changes or correspondence to:

Redmond, Attn: Production Coordinator
1105 Media, Inc.
9121 Oakdale Avenue, Suite 101
Chatsworth, CA 91311
Tel: 818-734-1520 x164
Fax: 818-734-1528

Email: redmondadproduction@1105media.com

▶ FTP File and Upload Information

Name your files with the magazine name, issue date and project name. All uploads should be followed by either a confirmation phone call or email message to your Production Coordinator to verify the file has been sent.

It is important that the uploaded file is placed in the designated directory for expedient access.

Host: <ftp://ads.1105media.com/>

User ID: 1105user

Password: 1105pass

Directory: /1105external/production/(publication folder)

▶ Pre-press

Ads requiring work to be done (sizing, typos, etc.) by the publisher will incur an additional charge. Advertising files are stored by the Publisher for one year, then deleted.

▶ Proofs

Provide two digital color proofs at 100% size, created from the supplied digital file, on a contract-quality, digital halftone proofing system in accordance with SWOP web coated standards (AGFA Pressmatch, Kodak Approval, DuPont Waterproof, etc.).

Laser or inkjet proofs are not considered accurate in color and are supplied for content confirmation only. If supplied, the Publisher is not responsible for color variances between the digital file and final color reproduction.

IMPORTANT NOTE: If proofs are not supplied, the Publisher reserves the right to have them made at the Advertiser's expense, and make-goods due to reproduction quality will not be honored.

▶ Digital Advertising Resources

1105 Media, Inc. publication's Media Kits and Ad Specifications

<http://www.101com.com/services/DigitalAdRes.aspx>

Digital Distribution of Advertising for Publications (DDAP)

<http://www.ddap.org>

Specifications Web Offset Publications (SWOP)

<http://www.swop.org>

<http://www.swop.org/certification.html>

Adobe Acrobat

<http://www.adobe.com/products/acrobat/main.html>