

▶ Multi-Page Bind-In Insert Specifications to Print

Effective January 2006

T · H · E Journal

In order to insure your insert is accommodated correctly in our publications, please observe the following requirements. If you have any further questions, please contact your publication Production Coordinator.

These specifications are for permanently bound, full-size inserts specifically prepared for a 1105 Media, Inc. publication. Inserts meeting these specifications will trim flush with the magazine. See additional specifications for magna-stripped or tipped inserts.

Magazine Trim Size:	8" x 10 ³ / ₄ "	Binding Lap:	3/8"
Head Trim:	1/8"	Foot Trim:	1/8"
Face Trim:	1/8"	Jog Direction:	Head
Minimum trimmed size:	4 ¹ / ₂ "H x 5 ³ / ₄ "W (includes 3/8" binding lap)		

▶ Quantity

Stated circulation PLUS any bonus circulation PLUS 3%. (Confirm on specific issue.)

▶ Due Date

All digital files are to be received at least two weeks prior to our mailing date. Contact your Production Coordinator for exact due dates.

▶ Pre-Approval

All anticipated inserts MUST be approved in advance, in writing, by the 1105 Media, Inc.'s Production Coordinator. Otherwise, slowdown or increased bind-in charges may apply. Supply two paper dummies produced to desired size and paper stock.

Send samples to: *THE Journal*, Attn: Production Coordinator,
1105 Media, Inc., 9121 Oakdale Avenue, Suite 101, Chatsworth, CA 91311

▶ Perforation (optional)

Bind edge perforation should be a minimum of 1/4" from the bind edge of the unbound card. Perforations should not exceed 50% cut (50% paper). Do not perf on the bind edge/fold.

▶ Media Shipping (not including pre-printed outserts)

Digital files should be provided on the following media: Macintosh formatted 100MB or 250MB Zip or CD-ROM. Please label media with the magazine name, issue date and advertiser name. Include a laser of the media directory with all contents. Ads requiring work to be done by the Publisher will incur an additional charge. Media and advertising materials are kept by the Publisher for one year then destroyed. Return material requests must be made in writing and are shipped C.O.D.

Send Materials To:

Production Coordinator
THE Journal, (Issue Date)
1105 Media, Inc.
9121 Oakdale Avenue, Suite 101
Chatsworth, CA 91311
Tel: 818-734-1520 x112
Fax: 818-734-1528
Email: thejournaladproduction@1105media.com

Media, files and proofs should be securely packed and shipped. Contents of the package should be identified on the outside as to publication date and type of material contained within. Please include the magazine name and issue date on all packages.

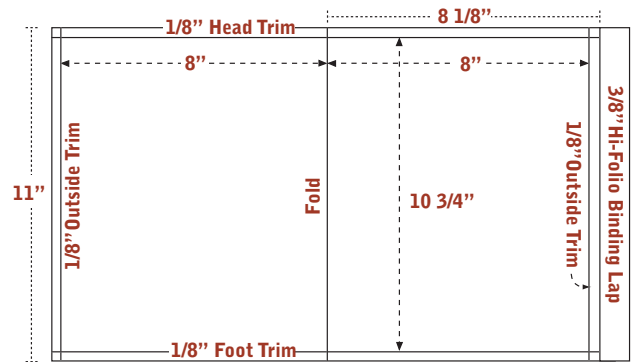

Flat Size: 16⁵/₈" x 11", includes bleeds and binding lap.

▶ Stock

Standard paper weight is 70# text. Please confirm stock acceptability in advance.

▶ Safety

Keep live copy at least 1/8" from the trim size.

▶ File Format

We support files generated by Adobe Acrobat using the 1105 Media Print Driver and 1105 Media Job Option Settings for Distiller, with specifications as listed below.

Download printer driver & distiller settings from our web site at:
<http://www.101com.com/services/DigitalAdRes.aspx>

In order to generate printable PDFs, it is important that the native file (QuarkXPress, Adobe InDesign or Pagemaker) is prepared accordingly.

Preparing native files for printable PDFs:

- Multiple pages need to be submitted as single page files
- Set bleeds 1/8" beyond trim
- All images/scans must be in CMYK mode, 300 dpi resolution
- DO NOT use stylized fonts
- Embed all fonts
- Rules should be .25 point or thicker
- All elements must be placed at 100% size
- Avoid rotation and cropping of images in layout program
- Do not nest EPS files in other EPS files
- Four-color solids should not exceed SWOP density of 280%

Preparing a PDF file (Preferred format):

- Use 1105 Media PPD Print Driver
- Use 1105 Media Job Option Settings for Distiller
- Set crop marks with a 12 point offset
- PDF file needs to be 1 inch larger than trim size of magazine and include crop marks

Preparing an EPS file (Optional alternative format):

- EPS file formats from Adobe Illustrator, Adobe Photoshop or Macromedia Freehand must be a high resolution CMYK EPS file, layers flattened with fonts converted to outlines or paths.

▶ Contact Information

Direct all questions, changes or correspondence to:

THE Journal
Attn: Production Coordinator
1105 Media, Inc.
9121 Oakdale Avenue, Suite 101
Chatsworth, CA 91311
Tel: 818-734-1520 x112
Fax: 818-734-1528

▶ FTP File and Upload Information

Name your files with the magazine name, issue date and project name. All uploads should be followed by either a confirmation phone call or email message to your Production Coordinator to verify the file has been sent.

It is important that the uploaded file is placed in the designated directory for expedient access.

Host: ftp://ads.1105media.com/

User ID: 1105user

Password: 1105pass

Directory: /1105external/production/(publication folder)

▶ Pre-press

Ads requiring work to be done (sizing, typos, etc.) by the publisher will incur an additional charge. Advertising files are stored by the Publisher for one year, then deleted.

▶ Proofs

Provide two digital color proofs at 100% size, created from the supplied digital file, on a contract-quality, digital halftone proofing system in accordance with SWOP web coated standards (AGFA Pressmatch, Kodak Approval, DuPont Waterproof, etc.).

Laser or inkjet proofs are not considered accurate in color and are supplied for content confirmation only. If supplied, the Publisher is not responsible for color variances between the digital file and final color reproduction.

IMPORTANT NOTE: If proofs are not supplied, the Publisher reserves the right to have them made at the Advertiser's expense, and make-goods due to reproduction quality will not be honored.

▶ Digital Advertising Resources

1105 Media, Inc. publication's Media Kits and Ad Specifications

<http://www.101com.com/services/DigitalAdRes.aspx>

Digital Distribution of Advertising for Publications (DDAP)

<http://www.ddap.org>

Specifications Web Offset Publications (SWOP)

<http://www.swop.org>

<http://www.swop.org/certification.html>

Adobe Acrobat

<http://www.adobe.com/products/acrobat/main.html>